

This publication assists applicants for Year 7 entry to selective high schools to become more familiar with the Selective High Schools Test.

Some of the items have not been included for copyright reasons. Items that assess reading will be available at a later date.

In the actual Selective High Schools Test there are 45 questions in reading, 40 in mathematics and 60 in general ability.

The Selective High Schools Test measures ability and is set to discriminate at a very high level. Students who are accustomed to answering most questions in tests correctly should not be discouraged if they get a number of questions wrong. It is very rare for even the highest scoring candidates to score full marks on all components of the Selective High Schools Test.

Selective high school entry does not depend entirely on a student's performance in the Selective High Schools Test as school assessment scores in English and mathematics are provided by the primary schools. It is important to note that selection committees and appeals panels will not accept students' performance in this past paper as evidence of academic merit for the purposes of entry into a selective high school in any future year.

- 1 The side of each small square is 1 centimetre long.

The area of the leaf is about

- A 9 square centimetres
- B 10 square centimetres
- C 14 square centimetres
- D 22 square centimetres

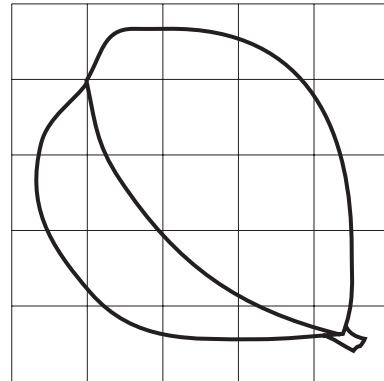

**Questions 2 and 3 refer to the following information:**

This grid can be used to describe a code.

For example, the letter E is (1,5); the number 7 is (3,0).

5	F	E	D	C	B	A
4	G	H	I	J	K	L
3	R	Q	P	O	N	M
2	S	T	U	V	W	X
1	3	2	1	0	Z	Y
0	4	5	6	7	8	9
	0	1	2	3	4	5

- 2 The code for the word PIN is

- A (3,2) (2,4) (4,3)
- B (2,3) (2,4) (3,4)
- C (2,3) (2,1) (4,3)
- D (2,3) (2,4) (4,3)

- 3 This message is in code:

(3,5)(3,3)(5,3)(1,5) (5,5)(1,2) (0,1)(2,3)(5,3)

It says

- A COME AT 3 PM
- B MEET AT 3 PM
- C COME AT 5 OK
- D MAKE IT 5 AM

- 4 A fish tank filled with water weighs 8 kg. When it is half full the tank and water together weigh 5 kg.

How much does the empty tank weigh?

- A 1.5 kg
- B 2 kg
- C 2.5 kg
- D 3 kg

Questions 5 to 7 refer to the following information:

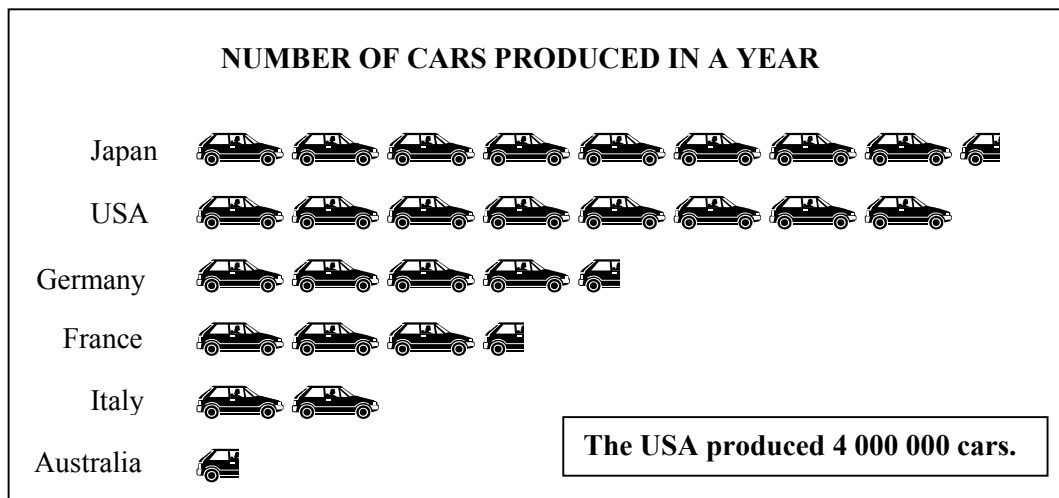

- 5 Which country produced seven times as many cars as Australia?

- A Italy
- B France
- C Germany
- D USA

- 6 How many cars did France produce?

- A 175 000
- B 350 000
- C 1 500 000
- D 1 750 000

- 7 How many more cars did Germany produce than Italy?

- A 500 000
- B 750 000
- C 1 250 000
- D 1 500 000

Questions 8 to 10 refer to the following information:

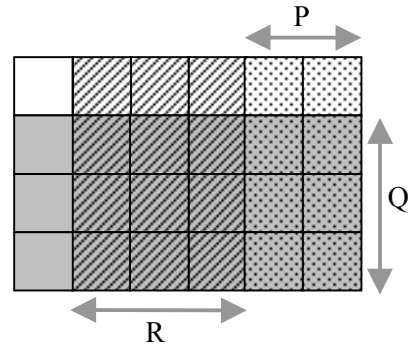
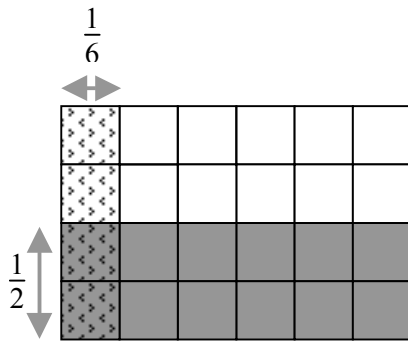

8 In the figure on the right **P** represents

- |                 |                  |
|-----------------|------------------|
| A $\frac{1}{3}$ | C $\frac{1}{6}$  |
| B $\frac{1}{4}$ | D $\frac{1}{12}$ |

9 In the figure on the right **Q** represents

- |                 |                 |
|-----------------|-----------------|
| A $\frac{3}{8}$ | C $\frac{2}{3}$ |
| B $\frac{3}{5}$ | D $\frac{3}{4}$ |

10 In the figure on the right **R** represents

- |                 |                 |
|-----------------|-----------------|
| A $\frac{1}{8}$ | C $\frac{1}{3}$ |
| B $\frac{1}{4}$ | D $\frac{1}{2}$ |

**ANSWER CHECK (Mathematics No. 1)**  
 Look on your Answer Sheet – the last question you answered should have been Question 10.  
 If it was, keep going.  
 If it wasn't, put your hand up for help.

**Questions 11 and 12 refer to the following information:**

Freda works at the supermarket. She stacks cans in a pattern like this:

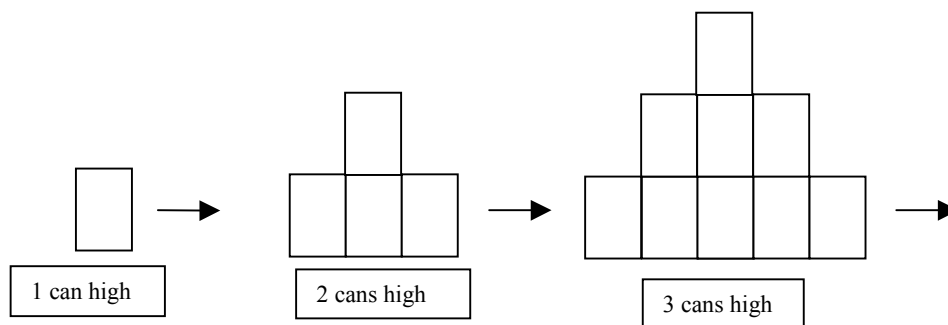

11 How many cans does Freda need to make a stack 5 cans high?

- A 15
- B 16
- C 21
- D 25

12 Freda has 55 cans altogether.

Using her pattern, how many cans high is the largest stack she can make?

- A 7
- B 10
- C 11
- D 18

---

13  $72 \div \Delta = 36 \div 4$

$\Delta =$

- A 2
- B 8
- C 9
- D 36

14 Cathy wants to buy 4 kg of canary seed.

How much will she save by buying the seed in 2 kg bags rather than 500 g bags?

CANARY SEED PRICES	
500 g bag	\$1.60
2 kg bag	\$5.20

- A \$1.20
- B \$2.40
- C \$3.60
- D \$10.40

**Questions 15 to 17 refer to the following information:**

Pria is a courier driver who travels between the five towns shown on this map. Distances are shown in kilometres. On average Pria travels 4 kilometres every five minutes; each stop for a pickup or delivery adds five minutes.

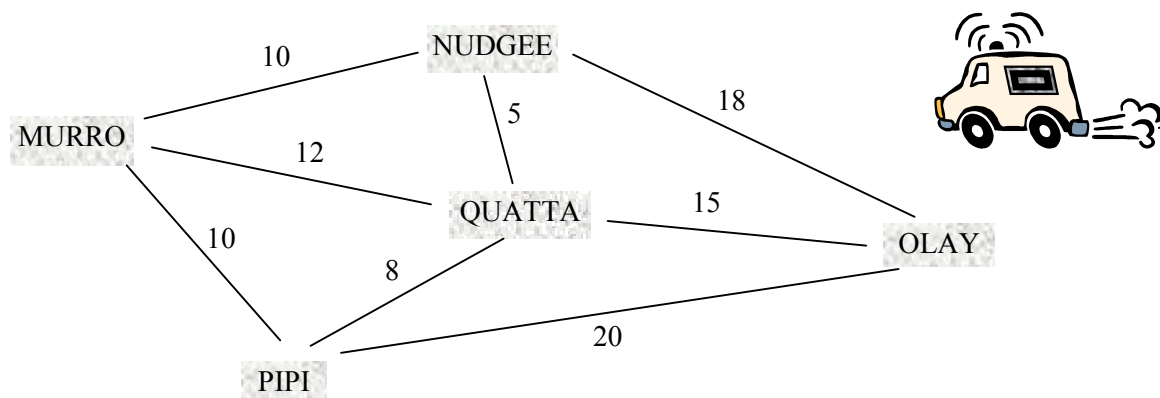

- 15 On Monday, Pria sets out from Murro to pick up at Quatta, deliver at Olay, and then return to Murro the shortest way.

The distance Pria travels is

- A 27 km.
  - B 42 km.
  - C 54 km.
  - D 57 km.
- 16 On Tuesday Pria travels from Murro, stops for a pickup at Quatta, Olay and Pipi, then returns to Murro.

What is the minimum time this trip will take?

- A less than 1 hour
  - B between 1 and  $1\frac{1}{2}$  hours
  - C between  $1\frac{1}{2}$  and 2 hours
  - D more than 2 hours
- 17 On Wednesday Pria travels from Murro to Quatta. Then the Murro – Quatta road floods, and he has to return to Murro via another route. All other roads are open.

On this trip, Pria travels a total of at least

- A 24 km.
- B 25 km.
- C 27 km.
- D 30 km.

18  $\frac{2}{\square} = \frac{\square}{18}$

$\square =$

- A 3
- B 6
- C 9
- D 36

**Questions 19 to 21 refer to the following information:**

This multiplication table shows that, for example,  $20 \times 0.2 = 4$ .  
Some of the table entries are missing.

multiplied by	→				
		20	2	0.2	0.02
↓					
20		400	40	4	0.4
2		40	4	0.4	
0.2		4	0.4		0.004
0.02		0.4	0.04	0.004	

19 Using the number pattern shown in the table

$0.2 \times 0.2 =$

- A 0.04
- B 0.4
- C 1
- D 4

20 From the information given in the table

$0.4 \div 0.2 =$

- A 0.02
- B 0.2
- C 2
- D 20

21 From the information given in the table

$200 \times 0.02 =$

- A 40
- B 10
- C 4
- D 0.4

- 22 Molly is going to Narnup 30 kilometres away.

At what speed will she need to travel to get there in 20 minutes?

- A 600 kilometres per hour
- B 90 kilometres per hour
- C 60 kilometres per hour
- D 15 kilometres per hour

23  $56 - (28 - 14) = (56 - \Delta) - 14$

$\Delta =$

- A 0
- B 14
- C 28
- D 42

**Questions 24 and 25 refer to the following information:**

Each square on this map is 1 square centimetre. Each centimetre on the map represents an actual distance of 2 kilometres.

The length on the map from S to T is about 3 centimetres.

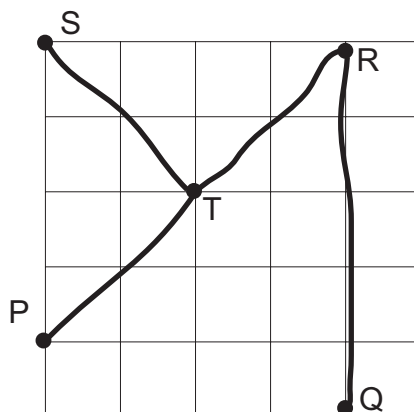

- 24 The actual distance from Q to R is about

- A 3 km
- B 5 km
- C 6 km
- D 10 km

- 25 The actual distance from P to R is about

- A 3 km
- B 6 km
- C 8 km
- D 12 km

**ANSWER CHECK (Mathematics No. 2)**

**Look on your Answer Sheet – the last question you answered should have been Question 25.**

**If it was, keep going.**

**If it wasn't, put your hand up for help.**



Questions 26 and 27 refer to the following information:

This container holds 1 litre of liquid.

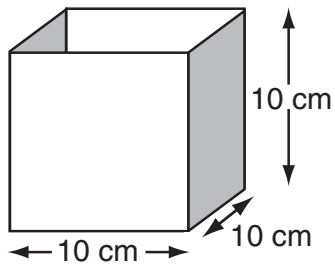

26 How much liquid does this container hold?

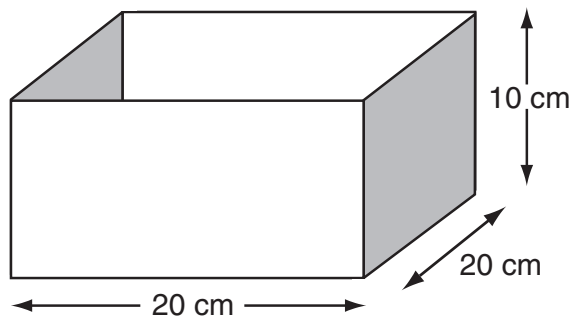

- A 2 litres
- B 3 litres
- C 4 litres
- D 8 litres

27 How much liquid does this container hold?

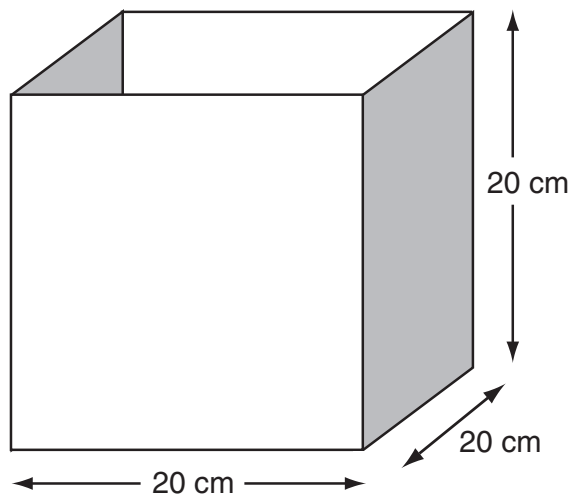

- A 4 litres
- B 8 litres
- C 9 litres
- D 16 litres

**Questions 28 to 30 refer to the following information:**

Many different paving patterns can be made using these paving stones:

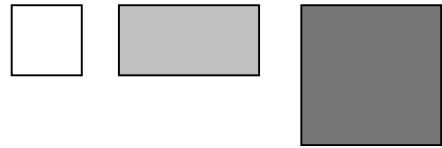

Here are two examples of a three-by-three pattern:

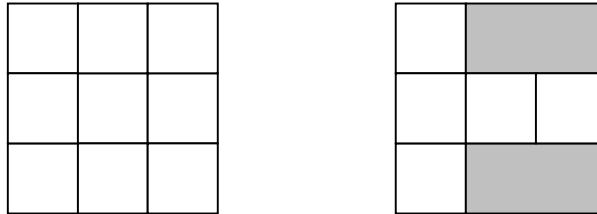

28 Which one of these patterns is **not** possible?

- A a two-by-three pattern using just three rectangles
- B a three-by-three pattern using two large squares and one small square
- C a three-by-four pattern using just two large squares and two rectangles
- D a three-by-three pattern using one small square, one large square and two rectangles

**Questions 29 and 30 refer to the following additional information:**

In a six-by-six 'Dutch' pattern, the three sorts of paving stones are used in a symmetrical arrangement to completely fill a square area.

A partly completed six-by-six pattern is shown.

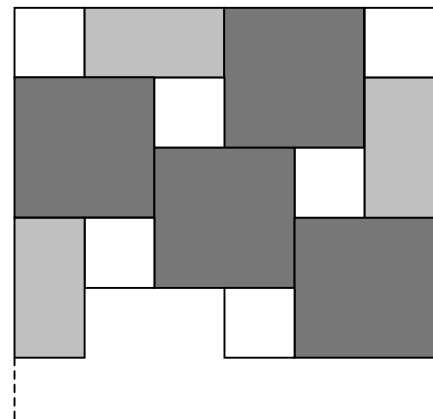

29 The stones required to complete this six-by-six pattern are

- A one small square and two rectangles.
- B one small square, one large square and one rectangle.
- C two small squares, one large square and one rectangle.
- D one small square, one large square and two rectangles.

30 Four small squares exactly cover one large square, and two small squares exactly cover one rectangle. A small square has each side 10 centimetres long.

What is the total area covered by a six-by-six pattern?

- A 600 square centimetres
- B 2400 square centimetres
- C 3600 square centimetres
- D 7200 square centimetres

**Questions 31 and 32 refer to the following information:**

The numbers in these boxes follow a pattern.  
Some of the entries are missing.

31 P =

- A 4
- B 6
- C 8
- D 26

32 Q =

- A 1
- B 4
- C 6
- D 9

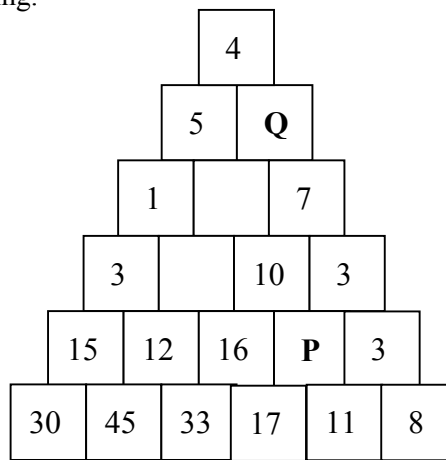

33 I am a 3D solid. I have nine edges and five faces.

Which shape am I?

- A triangular prism
- B rectangular prism
- C square pyramid
- D triangular pyramid

34 Don wanted to multiply by 25, but divided by 25 by mistake. His answer was 12.

What should his answer have been?

- A 144
- B 300
- C 600
- D 7500

35 These shapes follow a pattern.



What is the rule for the next shape in this pattern?

- A rotate the shape 60 degrees anticlockwise
- B rotate the shape 60 degrees clockwise
- C rotate the shape 45 degrees anticlockwise
- D rotate the shape 45 degrees clockwise

36 Some of the following nets will make a box like a cereal packet.

Which ones are they?

**I**

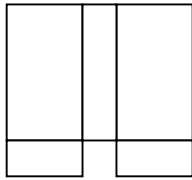

**III**

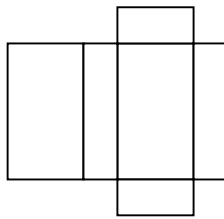

**V**

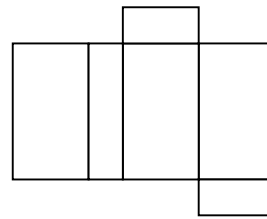

**II**

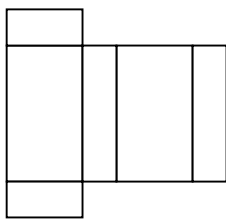

**IV**

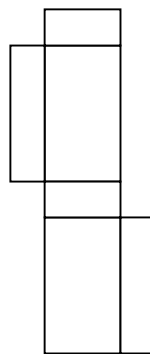

- A II and III only
- B I, II and IV only
- C II, III and IV only
- D III, IV and V only

37 This van weighs 2.2 tonnes.

Using your own weight as a guide, how many Year 6 students would be needed to balance it?

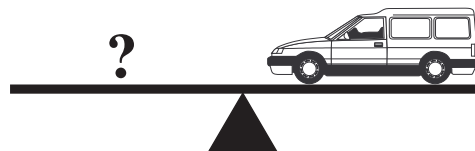

- A about 50
- B about 200
- C about 500
- D about 2000

38 This triangle has an area of 100 square centimetres.

A larger triangle is made: all the sides are increased to three times their original length.

The area of the larger triangle is

- A 300 square centimetres
- B 600 square centimetres
- C 900 square centimetres
- D 1200 square centimetres

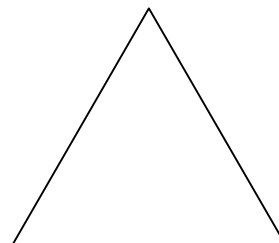

39 I am a 3D solid. I have two edges, two flat faces and a curved surface.

Which shape am I?

- A sphere
- B hemisphere
- C cone
- D cylinder

40 Magda has a tablecloth that fits on this tabletop with 20 centimetres hanging down over each edge.

She wants to put a lace border right around the edge of the tablecloth.

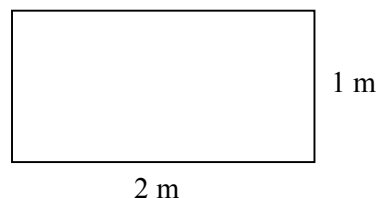

What is the length of the lace she needs?

- A 340 centimetres
- B 380 centimetres
- C 680 centimetres
- D 760 centimetres

**ANSWER CHECK (Mathematics No. 3)**  
**Look on your Answer Sheet – the last question you answered should have been Question 40.**  
**If it wasn't, put your hand up for help.**

**END OF TEST**

**LOOK BACK OVER YOUR WORK  
IF YOU HAVE TIME.**

<b>MATHS 2001</b>	
No.	KEY
1	C
2	D
3	A
4	B
5	B
6	D
7	C
8	A
9	D
10	D
11	D
12	A
13	B
14	B
15	C
16	B
17	C
18	B
19	A
20	C
21	C
22	B
23	A
24	D
25	<b>D</b>
26	C
27	B
28	B
29	C
30	C
31	B
32	A
33	A
34	D
35	A
36	C
37	A
38	C
39	D
40	D